



FAM110CS
Satin finish

General description

- Non-refrigerated wall-mounted water fountain with connection to the drinking water mains, made of stainless steel AISI 304, satin finish, 1 mm thick, satin finish.
- Ideal solution for public indoor and outdoor spaces such as waiting rooms, schools, universities, shopping centers, airports, sport facilities, factories, etc. Model suitable for public use with high strength and durability.
- Easily connected to the water mains, it provides a constant supply of water at room temperature.
- Designed to offer maximum hygiene and easy maintenance, this water drinking fountain feature softly rounded corners and a contoured bowl designed to minimize splashing.
- Equipped with a heavy-duty chrome plated brass faucet bubbler.

Components & Materials

- **BODY:** manufactured in stainless steel AIS 304, 1 mm thick, satin finish. Its contoured bowl minimizes splashing.
- **FAUCET BUBBLER:** with a manual timed push button is made of chrome plated brass.

Technical specifications

Stainless steel thickness	1 mm
Water inlet	3/8"
Water outlet	Ø 40 mm (1 1/2")
Net weight	2.9 Kg

Dimensions

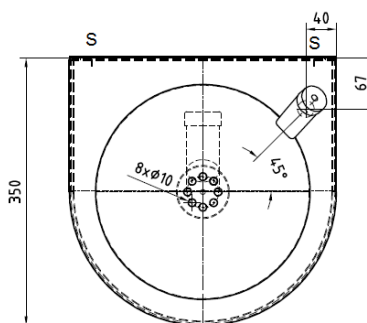
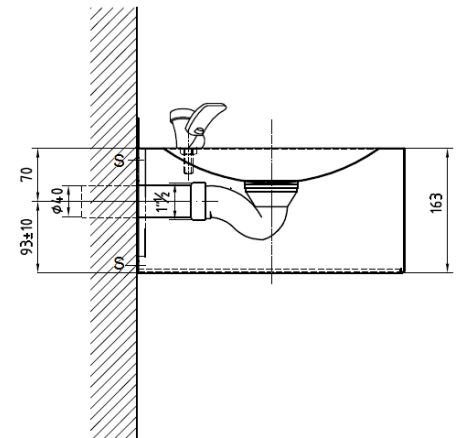
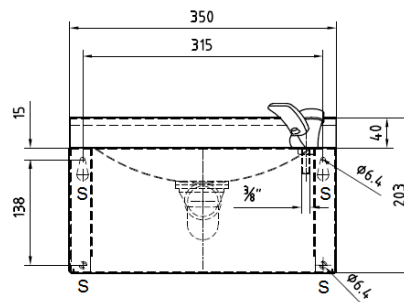

Dimensions ±4%

MOUNTING

Fix the wash basin on the wall using stainless steel screws (not supplied) through the corresponding holes (points indicated by an "S" in the upper figure).

OPERATION

Press the faucet bubbler button, bring the mouth near to the faucet bubbler and drink water at your convenience.